



Tower S3

USER MANUAL

HV Battery System
Tower S3-TS7/TS10/TS14/TS17/TS21
192-576V

Contents

Statement of Law	1
Revision History	1
Safety Handling Guide of Lithium Batteries	2
1 Introduction	4
Brief Introduction	4
Product Properties	4
Symbol Definition	4
Abbreviations in the Document	6
2 Product Specifications	7
System Performance Parameter	7
Battery Module	9
Battery Controller	11
3 Installation and Configuration	14
Environmental Requirements	14
Installation Spacing Requirements	15
Installation Location Precautions	15
Tools	16
Safety Gear	16
Unpacking	16
Equipment Installation	18
4 Maintenance	25
Trouble shooting	25
Replacement of Main Components	26
Battery Maintenance	27
5 Storage Recommendations	28
6 Shipment	28

Statement of Law

Copyright of this document belongs to Dyness Digital Energy Technology Co., LTD..

No part of this documentation is to be excerpted, reproduced, translated, annotated or duplicated in any form or by any means without the prior written authorization of Dyness Digital Energy Technology Co., LTD..

This product complies with the design requirements of environmental protection and personal safety. The storage, use and disposal of the products shall be carried out in accordance with the product manual, relevant contract or relevant laws and regulations.

Customers can check the related information on the Dyness Digital Energy Technology Co., LTD.website when the product or technology is updated.

URL:<http://www.dyness.com/>

Please note that the product can be modified without prior notification.

Revision History

Revision No.	Revision Date	Revision Reason
V0	2025.06.17	First Published

Safety Handling Guide of Lithium Batteries

DANGER

Before installation or operation carefully read the “Tower S3 ESS User Manual”. The batteries will produce high voltage DC power and might cause lethal voltage and electric shock.
Only qualified persons are allowed to wire the batteries.

WARNING

This product is a high voltage DC system, and should be operated by authorized persons only.

Risk of battery system damage or personal injury.

DO NOT disconnect while the system is running!

Keep all power sources off and verify that they are de-energized.

Battery damage may result in electrolyte leakage. If the electrolyte is leaked, do not touch the leaked electrolyte or volatile gas, and contact the after-sales service team for help immediately. If leaked material was touched accidentally, please follow the steps below:

- Inhalation of leaked material: Evacuate from contaminated area and seek medical assistance immediately.
- Eye contact: Flush with clean water for at least 15 minutes and seek medical assistance immediately.
- Skin contact: Wash the contact area thoroughly with soap and clean water and seek medical assistance immediately.
- Ingestion: Induce vomiting and seek immediate medical assistance.
- Do not move the battery system if it is connected with an external expansion module.

If you need to replace or add a battery, please contact the after-sales service center.

 CAUTION

Risk of battery system failure or life cycle reduction.

Before Connecting

Please check product and packing list after unpacking. If the product is damaged or parts are missing, please contact the local dealer.

Before installation, make sure that the grid is disconnected and the battery is switched off.

Do not invert the positive and negative cables and ensure there is no short circuit to the external device.

It is prohibited to connect the battery to AC power directly.

The battery system must be properly grounded and the resistance must be less than 1Ω .

Ensure that the electrical parameters of the battery system are compatible with the respective equipment.

Keep the battery away from water and fire.

During Use

If the battery system needs to be moved or repaired, the power must be disconnected and the battery must be switched off.

It is prohibited to connect different types of batteries.

It is prohibited to connect the battery to incompatible or faulty inverters.

It is prohibited to disassemble the battery (to avoid the warranty sticker to be removed or damaged).

In case of fire, only a dry powder fire extinguisher must be used, foam extinguishers are prohibited.

Please do not open, repair or disassemble batteries; this is reserved for Dyness staff or authorized personnel. We do not take any responsibility caused by violation of safety operation or equipment safety standards.

Maintenance

Please read the user manual carefully.

If batteries are stored for a long time, it is required to charge them every 10 months, and the SOC should be no less than 50%.

Do not expose cables outside.

All battery terminals must be disconnected for maintenance.

Please contact the supplier within 24 hours if there is something abnormal.

Warranty claims are excluded for direct or indirect damage due to items above.

1 Introduction

Brief Introduction

Tower S3 is a high voltage battery energy storage system based on lithium iron phosphate batteries, and it is one of the new products developed and produced by Dyness. They are used to provide reliable power for various types of equipment and systems. Tower S3 is especially suitable for high power, limited installation space, restricted load-bearing and long cycle life.

Product Properties

The entire module is non-toxic, non-polluting and environment-friendly. The anode material is made from LiFePO_4 with high security and long cycle life. The Battery Management System (BMS) comes with protective functions including over-discharge, over-charge, over-current and high/low temperature. The system automatically manages charging and discharging and balances current and voltage of each cell.

Flexible configuration, multiple battery modules can be connected in series for expanding voltage and capacity.







The adopted self-cooling mode rapidly reduces the system noise.

The module has less self-consumption, does not need to be charged up to 10 months; no memory effect, excellent performance of shallow charging and discharging.

The operating temperature range is 0 to +55°C, with excellent discharging performance and cycle life.

Small size and light weight, easy installation and maintenance of standard module.

Symbol Definition

DYNESS					
	TS7	TS10	TS14	TS17	TS21
Nominal Energy/kWh	7.1	10.7	14.2	17.8	21.3
Nominal Voltage/V	192	288	384	480	576
Rated Capacity/Ah	37	37	37	37	37
Ambient Temp/°C	0~50	0~50	0~50	0~50	0~50
IP Grade	54	54	54	54	54
Protective Class	I	I	I	I	I
   					
 					
<small>WWW.DYNESS-TECH.COM Dyness Digital Energy Technology Co., LTD.</small>					



Wi-Fi Logger
SN: R07E897536120030
Model: RBW-2-01101

Scan this QR code with the app for WiFi configuration



CAUTION



"FOR TOWER S3 ONLY – DO NOT USE WITH TOWER"

Figure 1-1 Battery energy storage system nameplate

Table 1-1 Symbol Definition

	Battery voltage is higher than safe voltage. Be careful of electric shock.
	Be careful with your actions and be aware of the dangers.
	Read the user manual before use.
	Do not dispose of batteries with the household waste; it must be recycled environmentally-friendly.
	At the end of the life cycle, batteries can continue to be used after being recycled. Please do not discard illegally.
	This product meets European directive requirements.

DYNESS IFpP13/143/275[(30S)1S]M/0+50/95

Product:	Rechargeable Li-ion Battery
Model:	HV9637S
Nominal Voltage:	96Vd.c.
Rated Energy/Capacity:	3.552kWh/37Ah
Max. Charge Current:	22A
Max. Discharge Current:	37A
Serial Number:	□

Dy Ness Digital Energy Technology Co., LTD.



Figure 1-2 Battery module label

Abbreviations in the Document

Table 1-2 Abbreviations in the document

Abbreviations in this document	Full name
BDU	Battery Disconnect Unit
BMS	Battery Management System
SOC	State Of Charge
PCS	Number of battery modules
DOD	Depth of discharge
NC	Normally closed

2 Product Specifications

System Performance Parameter

Table 2-1 Tower S3 system parameters

Model	TS21	TS17	TS14	TS10	TS7
Cell technology	LFP	LFP	LFP	LFP	LFP
Total energy stored [kWh]	21.31	17.76	14.21	10.66	7.10
Usable energy [kWh]	20.245	16.872	13.499	10.127	6.745
Recommend depth of discharge	95%	95%	95%	95%	95%
Max depth of discharge	100%	100%	100%	100%	100%
Module configuration	6 series	5 series	4 series	3 series	2 series
Voltage range [V/DC]	504~648	420~540	336~432	252~324	168~216
Battery system voltage (V/DC)	576	480	384	288	192
Battery system capacity (Ah)	37	37	37	37	37
Battery system charge voltage (V/DC)	648	540	432	324	216
Battery system charge current [A] (standard)	7.4	7.4	7.4	7.4	7.4
Battery system charge current [A] (normal)	18.5	18.5	18.5	18.5	18.5
Battery system charge current [A] (peak)	22	22	22	22	22
Battery system discharge minimum voltage (V/DC)	504	420	336	252	168
Battery system discharge current [A] (standard)	7.4	7.4	7.4	7.4	7.4
Battery system discharge current [A] (normal)	18.5	18.5	18.5	18.5	18.5
Battery system discharge current [A] (max)	37	37	37	37	37
Battery system max charge & discharge current [A]	22.5	22.5	22.5	22.5	22.5

Model	TS21	TS17	TS14	TS10	TS7
(in communication with inverter)					
Discharge temperature [°C]	-10~50	-10~50	-10~50	-10~50	-10~50
Charge temperature [°C]	0~50	0~50	0~50	0~50	0~50
Max discharge power [kW]	21.31	17.76	14.21	10.66	7.1
Max charge & discharge power [kW] (in communication with inverter)	12.78	10.65	8.52	6.39	4.2
Short circuit current [kA]	1.5	1.5	1.5	1.5	1.5
IP protection class	IP54	IP54	IP54	IP54	IP54
Dimensions [mm]	504*1520*380	504*1320*380	504*1120*380	504*920*380	504*720*380
Weight [kg]	263	223	183	143	103
Battery module name	HV9637S	HV9637S	HV9637S	HV9637S	HV9637S
Number of battery modules (pcs)	6	5	4	3	2

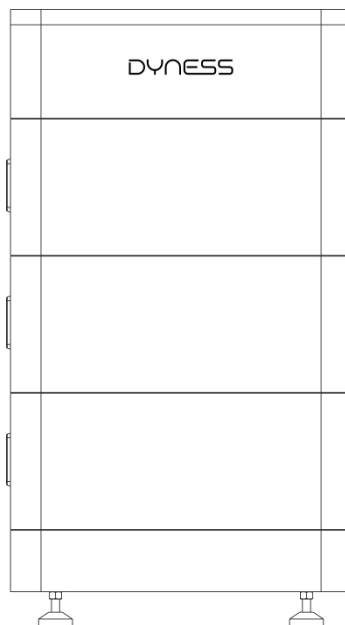

Figure 2-1 Tower S3 TS10

Battery Module

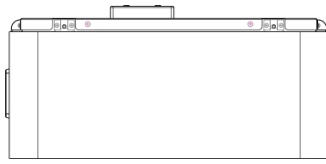

Figure 2-2 Battery module

Table 2-2 Product parameters

Module name	HV9637S
Cell technology	Li-ion (LFP)
Battery module energy (kWh)	3.552
Battery module voltage (V/DC)	96
Battery module capacity (Ah)	37
Number of battery module cells (pcs)	30
Battery cell power (Wh)	118.4
Battery cell voltage (V/DC)	3.2
Battery cell capacity (Ah)	37
Number of battery module cells in series (pcs)	30
Battery module charge voltage (V/DC)	108
Battery module charge current (normal) [A]	18.5
Battery module charge current (peak) [A]	22
Battery module discharge minimum voltage (V/DC)	84
Battery system discharge current (standard) [A]	7.4
Battery module discharge current (normal) [A]	18.5
Battery module discharge current (max) [A]	37
Dimensions (W*D*H, mm)	380*504*240
Pollution degree (PD)	II
Operating temperature (°C)	0~55
IP protection class	IP54

Module name	HV9637S
Weight (kg)	40

Composite connector - Plug

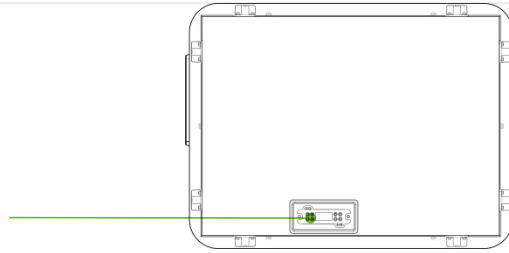

Figure 2-3 HV9637S connections on top

Composite connector-Socket

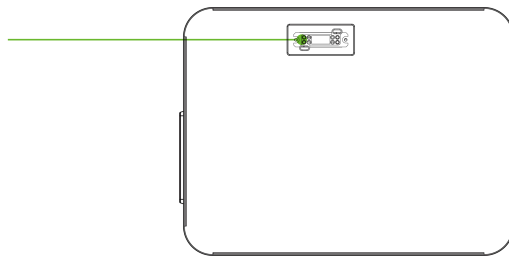

Figure 2-4 HV9637S connections at bottom

Table 2-3 Interface Definition

Name	Definition
Composite connector - Plug	Battery module output and communication interface
Composite connector - Socket	Battery module output and communication interface

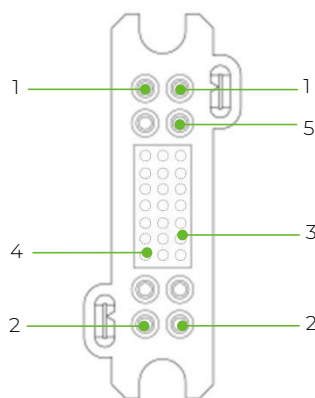

Figure 2-5 Composite Connector-Plug

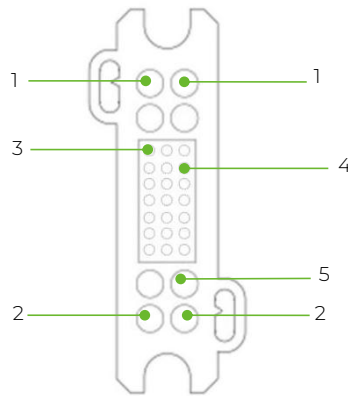

Figure 2-6 Composite Connector-Socket

Table 2-4 Port definition

No.	Composite connector - Plug	Composite connector - Socket
1	Positive output	Negative output
2	Negative output	Module negative
3	IM1	IM1
4	IP1	IP1
5	GND	GND

Battery Controller

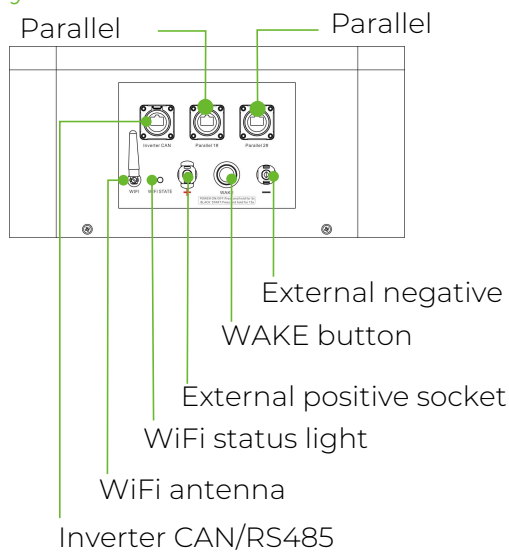

Figure 2-5 BDU right connections

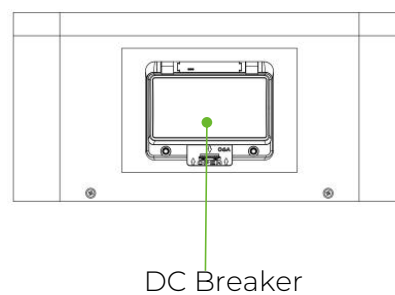

Figure 2-6 BDU left connections

Composite connector-
Socket

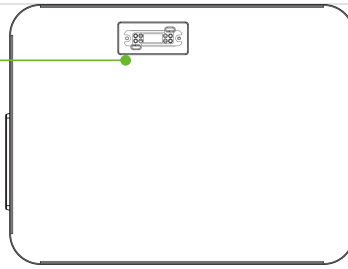

Figure 2-7 BDU bottom connections

Table 2-5 Interface Definition

Name	Description
Parallel 1#	Parallel communication connection of multi cluster systems
Parallel 2#	Parallel communication connection of multi cluster systems
Inverter CAN/RS485	RJ45 communication port between battery system and inverter
External positive socket	Connect battery system to inverter positive terminal
WAKE button	Press and hold this button for 5s to start the battery system
External negative socket	Connect battery system to inverter negative terminal
WiFi status light	Display current WiFi status
WiFi antenna	Receiving and sending WiFi signals
DC breaker	The master switch of the battery system, you must switch it on before switching on the Power On and Power WAKE switches; short circuit protection

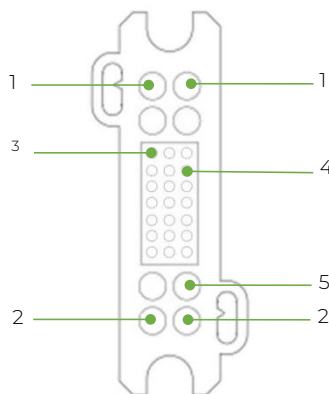

Figure 2-8 Composite Connector-Socket

Table 2-6 Port definition

No.	Definition
1	Negative output
2	Positive output
3	IM1
4	IP1
5	GND

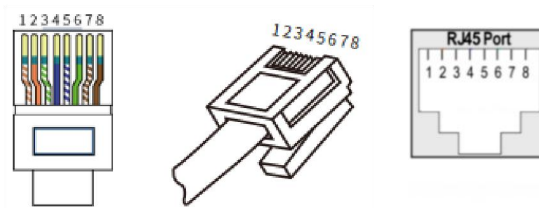

Figure 2-9 “Inverter CAN/RS485” port pins

Table 2-7 Definition of “Inverter CAN/RS485” port pins

PIN	Color	Definition
PIN1	Orange/White	485_B
PIN2	Orange	485_A
PIN3	Green/White	Reserved
PIN4	Blue	CANH
PIN5	Blue/White	CANL
PIN6	Green	NC
PIN7	Brown/White	NC
PIN8	Brown	NC

3 Installation and Configuration

Environmental Requirements

**DANGER**

Cleanliness

The battery system has high voltage connectors. The environmental conditions will affect the isolation of the system.

Before installation and switch-on, dust and swarf must be removed to keep the system clean. The environment must be dust-proof to a certain extent.

Dust and humidity must be regularly checked during continuous operation of the system.

Fire Protection System

Rooms are recommended to be equipped with a fire protection system or fire extinguishers (dry powder fire extinguishers are recommended). The fire protection system should be regularly inspected to ensure normal operation.

Local requirements are important to follow. Please refer to the local requirements for the use and maintenance of fire protection equipment.

Recommended but not a must for Dyness warranty.

Grounding System

Make sure that the grounding point for the battery system is stable and reliable before installation. If the battery system is installed in an independent equipment cabin (e.g. container), make sure that the grounding of the cabin is stable and reliable.

The resistance of the grounding system must be $\leq 1\Omega$.

**CAUTION**

Temperature

Tower S3 system operating temperature range: 0°C to +55°C; Optimal temperature:

18°C to 30°C; Exceeding the working temperature range will cause over-temperature/under-temperature alarms or protection of the battery system which may lead to shortening the life cycle.

Cooling System

It is essential to equip a cooling system to keep the battery system in a relevant temperature range. Over-temperature/ under-temperature alarms or protection of the battery system may lead to shortening the life cycle.

Heating System

It is essential to equip a heating system to keep the battery system in a relevant temperature range. If the temperature is below 0°C, the system may shut down for protection. It is necessary to open the heating system first. Exceeding or falling below the operating temperature range will cause over-temperature/under-temperature alarms or protection of the battery system may lead to shortening the life cycle.

Installation Spacing Requirements



Please note that the battery should be installed with a minimum safe clearance from the surrounding equipment or battery. Please refer to the minimum clearance diagram below.

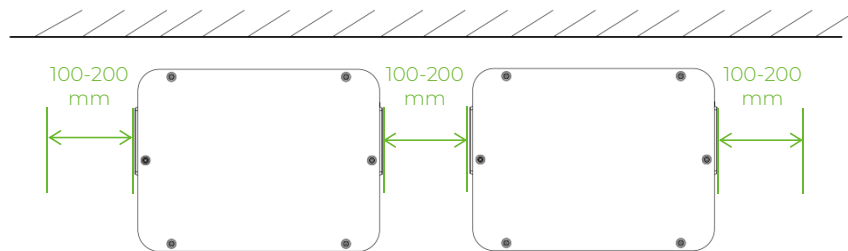

Figure 3-1 Minimum spacing

Installation Location Precautions

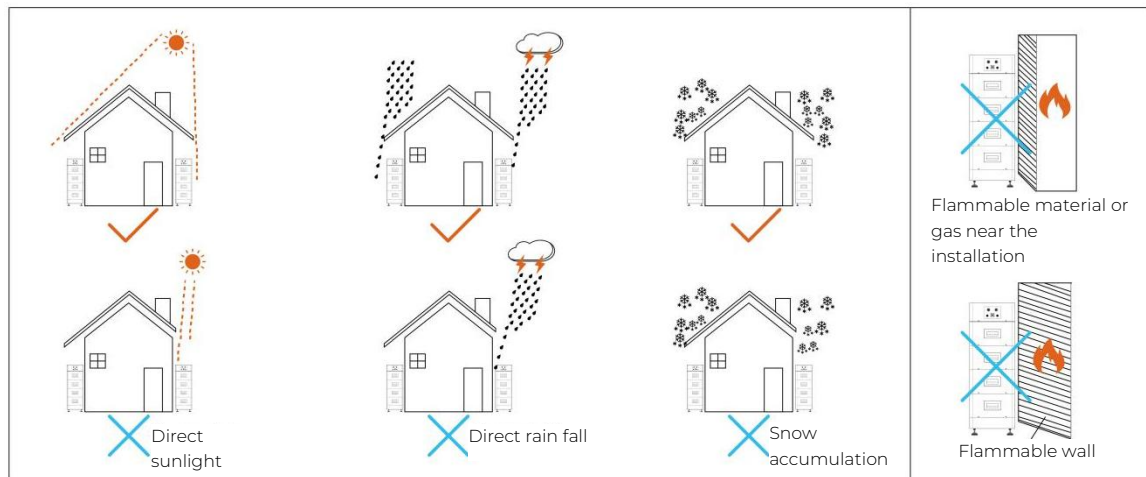

Figure 3-2 Installation location

Tools

The following tools are required to install the battery pack:

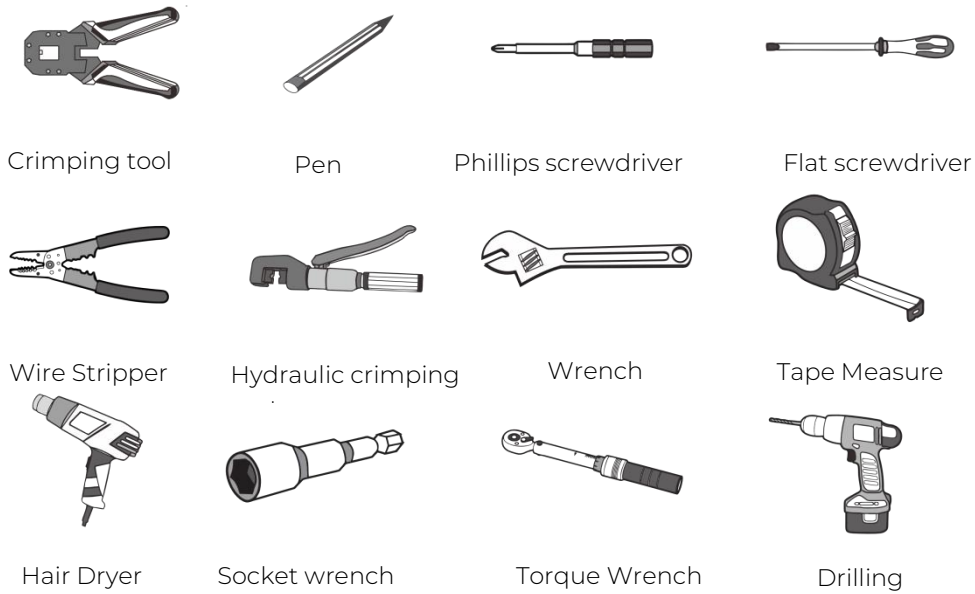



Figure 3-3 Installation tools

 **CAUTION**
 Use properly insulated tools to prevent electric shock or short circuit.

Safety Gear

We recommend wearing the following safety gear when working with batteries:



Figure 3-4 Safety gear

Unpacking









When the battery system is delivered at the installation site, unloading should be performed according to the rules and regulations, to prevent being exposed to direct sunlight. Batteries should not be installed in locations in direct sunlight. See Figure 3-2 Installation location precautions.



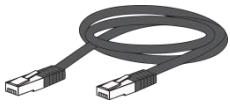





Before unpacking, the total number of boxes must be reconciled according to the shipping list attached to each package, and the boxes must be checked for good condition.

Handle all items carefully and protect the surface coating of the items.

After opening the boxes, the installer should read the technical documentation, verify the list, ensure that the items are complete and undamaged according to the configuration table and packing list. If there is damage to the internal packaging, it should be checked and recorded in detail.

Table 3-1 Packing List

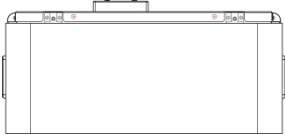
Item	Specifications	Quantity	Image
BDU	Tower S3 SBDU	1	
A	Communication cable to inverter	Standard, black /L 2000mm /RJ45 plug at both sides	1 
	Communication cable to inverter or parallel communication	Standard, black /L 2000mm /CAN plug at both sides	1 
	Power cable-positive	Positive cable 6mm ² , red, 2m	1 
	Power cable-negative	Negative cable 6mm ² , black, 2m	1 
	Power cable connector	To positive battery pole	1 
	Power cable connector	To negative battery pole	1 
	Communication connector to BDU	RJ45 waterproof connector	2 
	CAN resistor	RJ45-CAN-120, Pin7&8	1 

	screw	Cross Recessed Pan Head three combination Screw M6*14	1	
	screw	Countersunk head Phillips screws M4*12	4	
	Terminal	OT4-6	2	 DYNES
	User Manual	User Manual	1	
	Warranty card	/	1	
	Packing list	/	1	
	Battery	HV9637S 96V/37Ah	1	
B	screw	Countersunk head Phillips screws M4*12	4	
	Packing list	/	1	

Equipment Installation

Installation Preparation

1. Make sure that the environment meets all technical requirements.
2. Prepare equipment and tools for installation.
3. Confirm that the DC breaker is in OFF position.

Mechanical Installation .

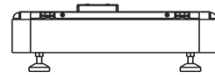
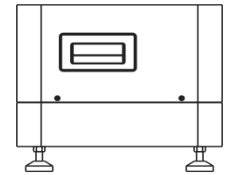
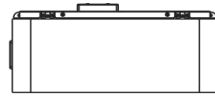

1. Determine Tower S3 placement.
2. Separate the BDU from the battery base.

3. Place battery module on the battery base (The height of feet on the base can be adjusted).

4. Fix each module with 4 screws.

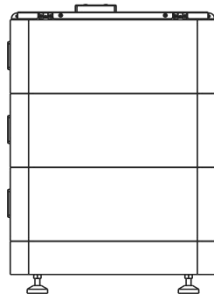

N*Battery
Module
HV9637S

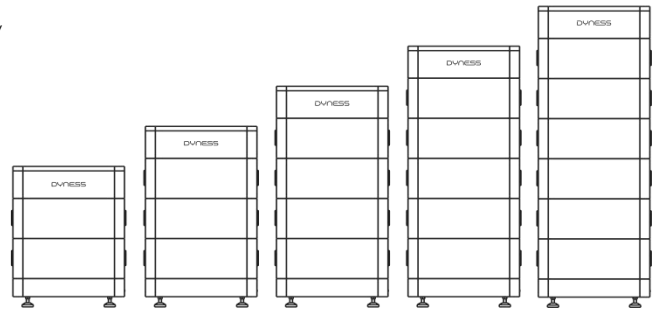

5. Place Tower S3 BDU on battery module.

Figure 3-5 Mechanical installation

DANGER

The battery system is a high voltage DC system. Ensure that the grounding surface of Tower S3 is stable and reliable.

Please confirm that the battery system is switched off before connecting. Electric shock and damage to the inverter may be caused if the battery is connected directly without being switched off.

Otherwise, the system cannot work properly. The voltage of the battery is too high, please pay attention to self-protection during measurement.

! WARNING

A single battery module weighs 41kg. It is necessary to install battery modules with helpers if no lifting equipment is available, even more so if the battery modules are installed higher up.

Double check all the power and communication cables. Make sure that the voltage of the inverter is at the same level as the battery system.

- Switch on the inverter, and make sure that all power equipment is working normally.
- Start the battery system. See Table 3-2 Battery system self-test step 2.

! DANGER

DO NOT MIX Tower S3&Tower. SERIES/PARALLEL CONNECTION PROHIBITED.

Table 3-2 Battery system self-test

Step 1 Electrical installation

Battery system grounding

(After the HV9637S module is stacked, it is fixed with two screws each left and right. Then the shell surfaces of the upper and lower modules are screwed together. There is a special docking point at the bottom of the battery base. See bottom right.)

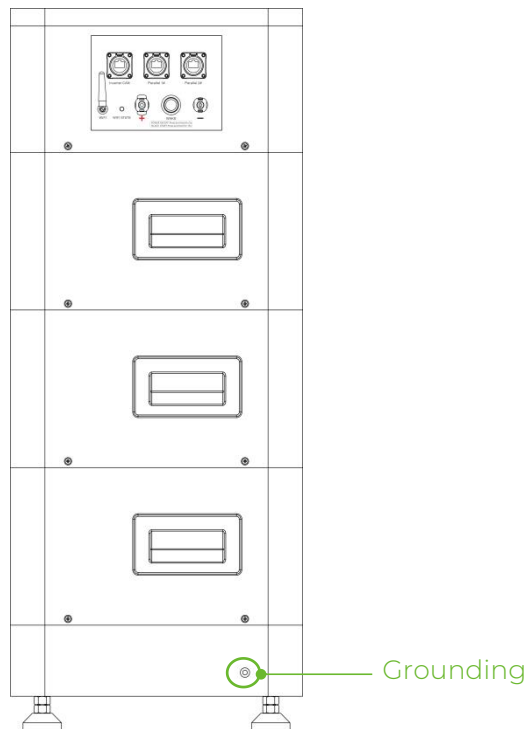

Step 2 Battery system self-test

1. Switch the DC breaker of the BDU on.

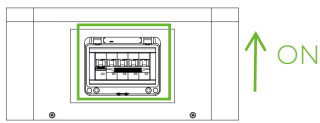

2. Press and hold the WAKE button for approx 15s, battery power on.



3. Check the system output voltage.

- Use a multimeter to measure the output voltage on the positive and negative ports of the BDU.
- The output voltage should be in the voltage range as shown in “Table 2-1 Tower S3 system parameters”.

4. Press and hold the WAKE button for approx 15s, battery shutdown.



5. Switch the BDU DC BREAKER to OFF position.

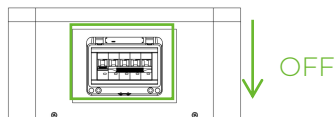

DO NOT switch off during normal operation.

Table 3-3 WAKE button status indicators

- If the red light remains on, it indicates a battery failure.
- If the green light *flashing*, it indicates that the battery status is normal and the communication connection with the inverter has failed.
- If the green light remains on, it indicates that the battery and inverter are connected properly and the battery can be used normally.

DANGER

Ensure ON/OFF switch is turned on before waking up the battery. Otherwise it will affect the auto test process and cause danger.

DO NOT switch off the ON/OFF switch during normal operation, only in emergencies. Otherwise it will cause the battery current to surge.

CAUTION

If the DC breaker trips because of over-current or short circuit, you must wait for 30 minutes to switch it on again, otherwise it may cause damage to the breaker.

Step 3 Connecting inverter

1. Connect the external power cable to the inverter
(If the 2m power cable is too short, please use a power cable with same specifications with max 3m length).

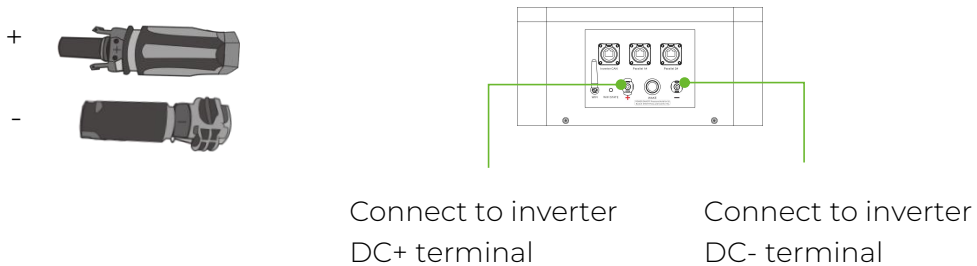

2. Connect the EXT-CAN/RS485 communication cable to the inverter RJ45 CAN/RS485 port.



CAUTION

We recommend an external DC breaker operating both positive and negative conductors simultaneously between BDU and inverter. After waking up the BDU and ensuring that the BDU is pre-charged, it can be switched on.

Step 4 Parallel system

Important:

The parallel connection of the Tower S3 series and all other related work are only allowed by professional and qualified electricians.

The total voltage difference between clusters is less than 20V; SOC of each cluster should be 100% and time interval between newly added cluster and existing cluster should be less than 6 months.

Maximum 12 tower S3 clusters are allowed to be connected in parallel.

1. Parallel wiring

The general configuration diagram of the Tower S3 in parallel connection is as under.

Take three clusters for example:

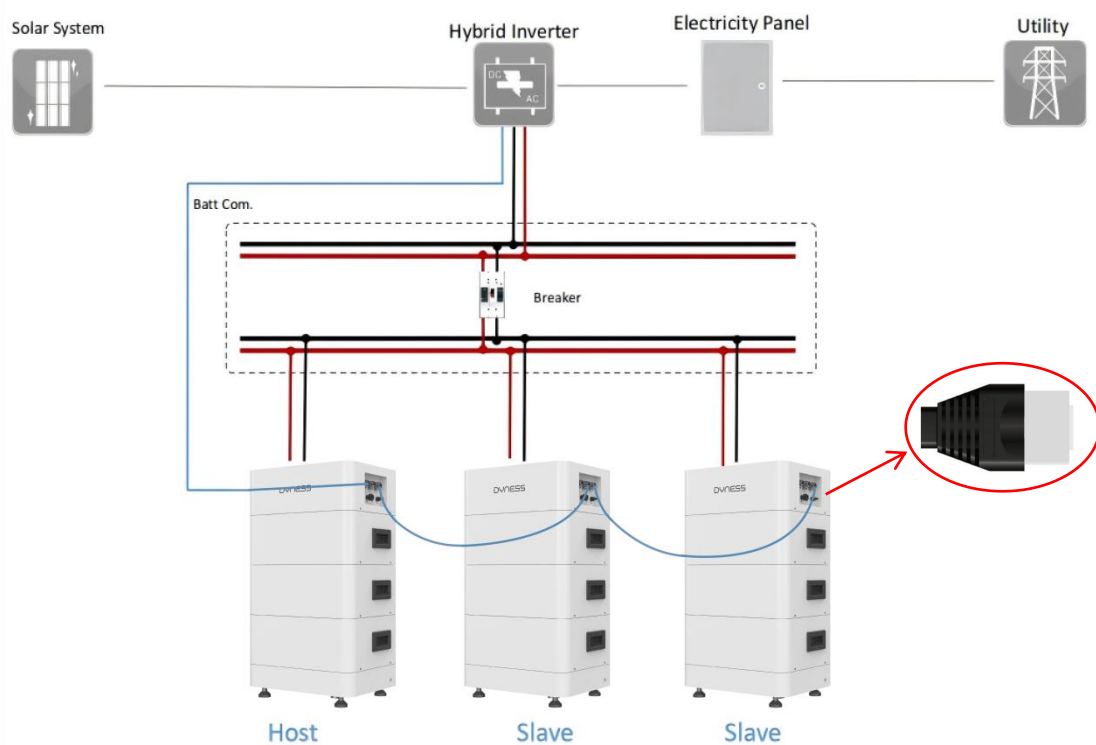
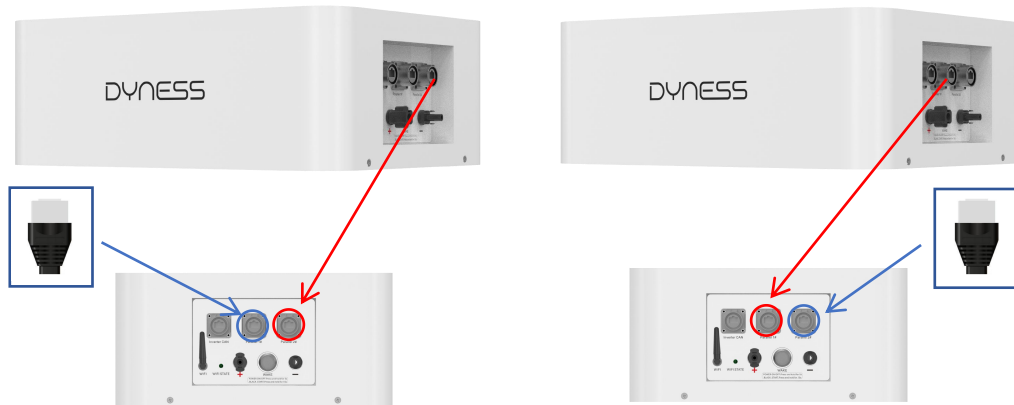

Figure 5-6 The general configuration diagram of the Tower S3

Communication network cable connection between Tower S3 and Tower S3:
standard network cable

For multi cluster parallel systems, the communication line connection between clusters is Host's Parallel 2 to the second cluster's(Slave) Parallel 1 and so on. Then connect a 120 Ω CAN resistor to the port of the host parallel 1 and the last slave parallel 2. Ensure the stability of CAN communication.

Step 4 Parallel system



Communication network cable connection between inverter and Tower S3(Host):

CAN/RS485 of the BDU of Tower S3 to the communication port of the inverter.

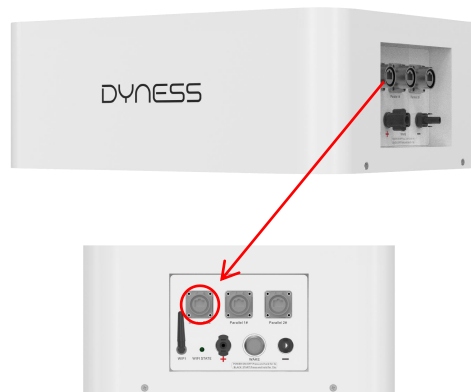

Attention

- The Tower S3 in parallel must be of the same model and same capacity.
- During capacity expansion, make sure SOC of each module is 100%.
- Power on sequence of multiple clusters: Start the Slave first, then start the Host last.

4 Maintenance

Trouble shooting



The battery system is a high voltage DC system. Must make sure that the grounding surface of Tower S3 is stable and reliable.
Please confirm that the battery system is switched off before connecting. Electric shock and damage to the inverter may be caused if the battery is connected to the inverter directly without being powered off.
Otherwise, the system cannot operate properly. The voltage of the battery is too high, please pay attention to self-protection during measurement.

No.	Problem	Possible Reason	Solution
1	Pressing the "WAKE" button does not turn on the device, and the light remains off.	The BDU DC breaker is not switched on.	Switch the BDU DC breaker on.
		The battery voltage is severely low (<80V) or damaged.	Contact the battery manufacturer for further inspection.
2	Pressing the "WAKE" button turn on the device, the light will turn on, but the display status of the light is red.	Improper placement of batteries and BDU during installation, resulting in misalignment of blind insertion pins.	Check the blind insertion pin and reset the misplaced blind insertion pin.
		Battery system protection.	Charge the battery to leave protection mode, or contact the battery manufacturer for further inspection.
3	The battery has no voltage output.	Battery changes into over-discharged protection.	Charge the battery to leave protection mode.
		Communication failure with inverter.	Check if the connection of the communication cable and PIN definition are correct.
4	Battery shutdown.	Inverter has an error.	Check for inverter errors and restore the inverter.
		BDU DC circuit breaker open circuit. Battery changes into	Switch the BDU DC breaker on. Charge the battery to

		over-discharged protection. Battery is in sleep mode.	leave protection mode. Press and hold the WAKE button for approx. 15s.
		The battery system has not undergone full charge calibration for a long time.	Perform a full charge calibration once.
5	SOC jump during battery charging and discharging process.	Inconsistent SOC of battery module.	The system performs 10 ~ 30 full charge balancing cycles (depending on the SOC difference of the module, the number of full charge balancing will vary); or fully charge each battery module separately with BDU and DC power supply.
		Differences in battery cell consistency or damage.	Contact the battery manufacturer for further inspection.

Replacement of Main Components

Replacing the Battery Controller (BDU)

 **WARNING**

Turn off the entire battery system. Ensure that the negative and positive terminals are de-energized.

- Press and hold the WAKE button for approx 15s, battery shutdown.

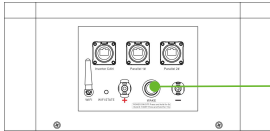

Press and hold for 15s

- Switch the BDU DC BREAKER to OFF position.

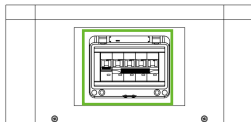

OFF
↓

- Disconnect the connecting cable.
- Remove the four screws on the BDU and remove the BDU from the system.

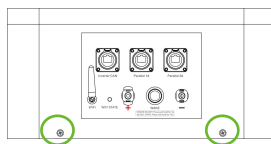

Figure 4-1 BDU right connections

- Exchange BDU. Then fix it with four screws.
- After replacing the new BDU, the battery self-test needs to be performed again (see Table 3-2 Battery system self-test).

Battery Maintenance



Battery maintenance should only be carried out by professional and authorized persons.

Switch off the battery system before maintenance.

Voltage check:

[Periodical maintenance] Check the voltage of the battery system with the monitoring software. Check whether the system voltage is normal. For example: Check whether the single cell voltage is out of range.

Voltage check:

[Periodical maintenance] Check the SOC of the battery system with the monitoring software. Check whether the SOC of the batteries is normal.

Cable check:

[Periodical maintenance] Visually inspect all cables of the battery system. Check whether the cables are broken, aging or loose.

Balancing:

[Periodical maintenance] The battery system will become unbalanced if it has not been charged fully for a long time. Solution: Perform balancing maintenance (fully charge) every 3 month. Generally this maintenance progress needs to be completed when external devices such as the monitoring software and battery and inverter have proper communication.

Output relay check:

[Periodical maintenance] Under low load (low current), check the output relay OFF and ON condition; listen if the relay clicks, which means that it switches off and on normally.

5 Storage Recommendations

For long-term storage (more than 3 months), the battery cells should be stored in following environment: temperature range 5 to 45°C, relative humidity <65% and no corrosive gases.

The battery module should be placed in temperature range 5 to 45°C, dry, clean and well ventilated environment. The battery should be charged to 50 - 55% SOC before storage.

We recommend activating the battery system (discharge and charge) every 10 months, Corresponding to the battery system that has been installed and used normally, it is necessary to regularly fully charge the battery to calibrate the SOC. It is recommended to fully charge and calibrate at least once every 2 weeks.



The lifespan of the battery will be greatly reduced if you do not follow above instructions to store the battery for a long term.

6 Shipment

The battery module is pre-charged to 50% SOC or according to customer requirements before shipment. The remaining capacity of battery cells is determined by the storage time and condition after shipment.

The battery modules meet UN38.3 certificate standard.

In particular, special rules for the carriage of goods on the road and the current dangerous goods law, especially ADR (European Convention on the International Carriage of Dangerous Goods by Road), as amended, must be observed.

DYNNESS

Address: No.688, Liupu Road, Guoxiang Street, Wuzhong Economic Development Zone,
Suzhou, Jiangsu, China
Email: service@dyness-tech.com
Tel: +86 400 666 0655
Web: www.dyness.com



Official Website



Digital version access